

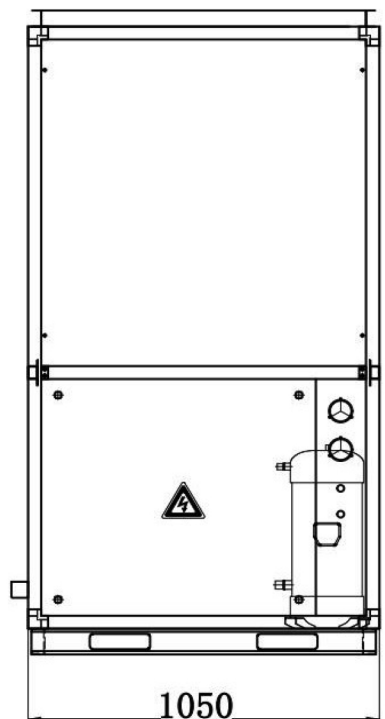

| Specification | | GA-08T |
|--|-----------|---|
| Total cooling capacity | MBH | 102.0 |
| | ton | 8.5 |
| Sensible cooling capacity | MBH | 55.3 |
| Total heat rejection | MBH | 128.7 |
| Dehumidification capacity | L/hr | 16.8 |
| | Pint/hr | 35.4 |
| | Gallon/hr | 4.4 |
| Supply air | cfm | 2150 |
| External static | Pa | 200 |
| Compressor consumption power | kW | 7.8 |
| Fan Motor consumption power | kW | 0.9 |
| Total consumption power | kW | 8.7 |
| Rated current | A | 27.6 |
| F.L.A | A | 39.0 |
| Power supply | V/Hz/Ph | 220/60/3 |
| Refrigerant | type | R410A |
| Air filter | type | MERV-8 |
| Protections | type | Phase Protection, High/Low Pressure Protection, Overload Protection, Compressor staged start, Compressor Auto-Protection, Fan Motor Auto-Protection |
| Condenser drain pipe diameter | inch | 3/4 |
| Net Weight | kg | 356 |
| Dimension(L*W*H) | mm | 1050*790*1950 |
| Air cooling with air cooled condenser | | |
| Total fan moter power | kW | 1.2 |
| Dimension(L*W*H) | mm | 1200*460*1340 |
| Net Weight | kg | 100 |
| Quantity to dehumidification system | Pcs | 1 |

Drawings

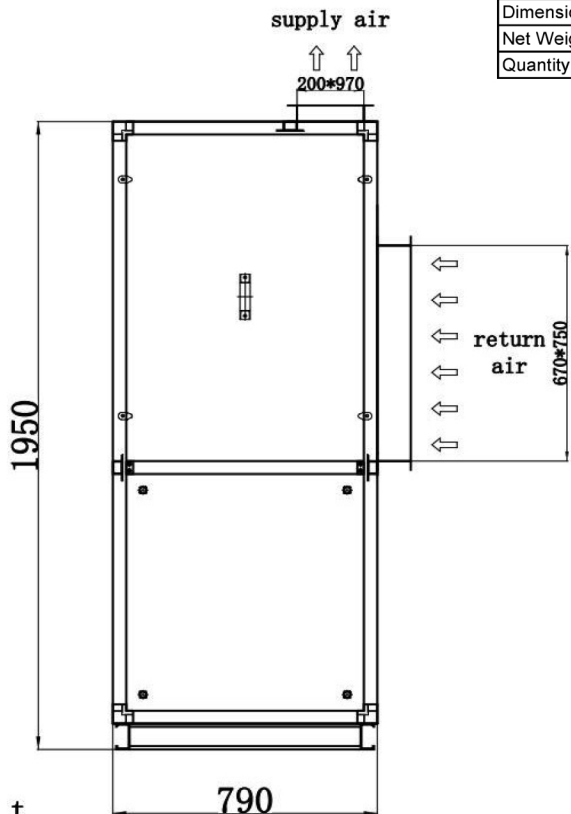

Air cooled condenser

