



HDE VARIABLE SPEED DIRECT DRIVE TOTALLY ENCLOSED FAN COOLED

TRIFOG-3G-6Z-2401P-VFD

1500 PSI MISTING PUMP MANUAL

**INCLUDING: SPECIFICATION DATA, GENERAL SAFETY PRECAUTIONS, OPERATION,
INSTALLATION , PARTS, MAINTENANCE & WARRANTY**

QUALITY MISTING PUMPS

DIRECT DRIVE MISTING PUMP SPECIFICATIONS

| PUMP | FLOW | MAXIMUM | MOTOR | SINGLE | MOTOR | MOTOR | NOISE | OIL | |
|------------------------|------|----------|-------|--------|---------|-------|-------|---------|----------|
| MODELS | GPM | PRESSURE | HP | PHASE | VOLTAGE | AMPS | RPM | DB(A) | CAPACITY |
| TRIFOG-3G-6Z-2401P-VFD | 3.0 | 1500 | 3.0 | 230 | 8.8 | 1725 | 68 | 8.5 oz. | |

FEATURES

- CAT PUMP
- TEFC MOTOR
- VARIABLE SPEED
- INLET SOLENOID VALVE
- LIQUID FILLED PRESSURE GAUGE
- TOTALLY ENCLOSED with INTERNAL FAN
- ACOUSTICAL INSULATION ON INSIDE COVER FOR LOW NOISE LEVEL
- POWDER COAT FINISH
- ON/OFF SWITCH

TECHNICAL DATA

| | |
|-------------------------|---------------|
| MAX. DISCHARGE PRESSURE | 1500 PSI |
| ELECTRIC MOTOR TYPE | TEFC |
| MOTOR OVERLOAD | AUTOMATIC |
| DUAL FILTRATION | 5 & 1 MICRON |
| INLET PSI RANGE | 30-60 PSI |
| MAX LIQUID TEMPERATURE | 145° F |
| WATER INLET VALVE | 3/8" SOLENOID |
| PRESSURE GAUGE | 0-2000 psi |
| SWITCH | ROTARY |
| 6 FT. POWER CORD | SJTW-105C |
| OIL CAPACITY | 8.5 oz |

DIMENSIONS

31.5" L x 16.5" W x 13" H



WEIGHT

Approx. 160 lbs.

PUMP OVERVIEW

31063 2.0 HP TEFC ELECTRIC MOTOR 230 Volt (for 1.5 GPM)

33055 RED CRANKCASE BREATHER CAP

30102 ON / OFF SWITCH

30376 INLET SOLENOID VALVE

57010 WATER INLET FILTER HOUSING

30375-C SOLENOID CORD

57011 5 MICRON CARTRIDGE

57006 1 MICRON CARTRIDGE

30082 (230 Volt) EXHAUST FAN

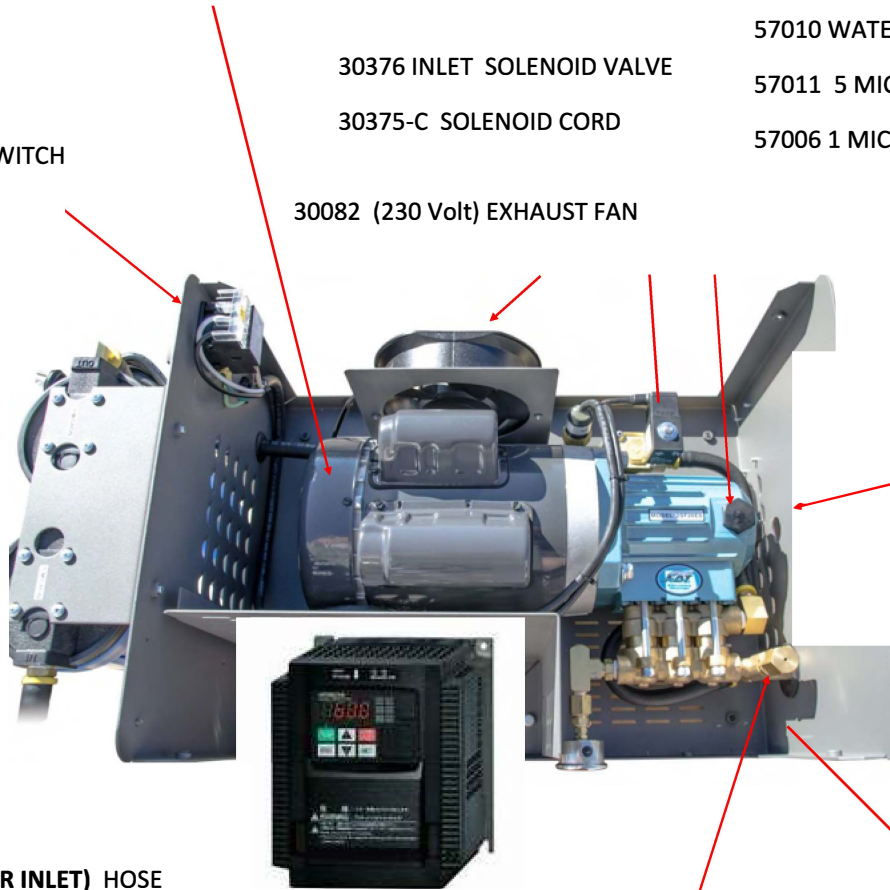

92241 OIL SIGHT GAUGE

57251 PRESSURE GAUGE

52623 COMP.NUT W/ SLEEVE (WATER OUTLET to MIST LINE)

44842 OIL DRAIN PLUG INSIDE HAND HOLE COVER

26038 (WATER INLET) HOSE
3/8" ID Per ft.

WJ200-007SF Hitachi VFD

66509 Pressure Transducer 4-20 ma 0-2000 PSI

30100 POWER CORD 12/3 230 Volt

PRESSURE REGULATOR is set at 1200 PSI. The pressure transducer is regulating the pressure at 1000 PSI

DO NOT ADJUST REGULATOR

QUALITY MISTING PUMPS

GENERAL SAFETY PRECAUTIONS

⚠ WARNING CAN cause DEATH, SEVERE INJURY or substantial property damage.

⚠ CAUTION CAN cause MINOR INJURY or property damage.

GENERAL SAFETY PRECAUTIONS

Consequently, it is essential to comply with the instructions in this manual as well as local and national rules and safety regulations.

⚠ WARNING **HAZARDOUS VOLTAGE.** Can cause serious injury or death. Disconnect power before servicing pump. Pump must be connected to a properly grounded circuit. Do not operate pump in wet conditions.

⚠ WARNING **MOVING PARTS.** Pump may start automatically. Disconnect power, before servicing. Lockout/Tag out misting pump.

HOT SURFACES. Can cause serious injury. Do not touch. Allow to cool before servicing.

⚠ WARNING **HIGH PRESSURE WATER.** Bypassing, modifying or removing safety/relief regulator valves can cause serious injury or death. Do not bypass, modify or remove safety/relief valves. If a leak should occur shut unit off before attempting to tighten any fittings or tube repairs. Do not change any pressure settings above maximum rating. Maximum pressure is 1000 PSI / 70 Bar

⚠ CAUTION **RISK OF LEAKING or BURSTING.** Use only suitable tubing and fittings acceptable for pressure of not less than the maximum allowable working pressure of the pump. Remove water from lines and filter bowls during winter months to prevent freezing damage to pump or tubing.

⚠ CAUTION **Install pump in a suitable place to prevent property damage in the event a leak should occur.**

⚠ WARNING **Electrical installation and service should be performed by a qualified electrician who is familiar with all applicable local, state and federal laws and regulations.**

GENERAL. The motor rating, as shown on the motor nameplate, and the power supply must have compatible voltage, phase and hertz characteristics.

WIRE SIZE. The electrical wiring between the power supply and electric motor varies according to motor horsepower and other factors. Install adequately sized power leads to protect against excessive voltage drop during start-up. Refer to the National Electric Code (NEC) for information on selecting the proper wire size and securing electrical connections. If you connect additional electrical equipment to the same circuit, consider the total electrical load when selecting the proper wire size.

DO NOT UNDERSIZE WIRING. DO NOT USE EXTENSION CORDS.

OPERATION

The TriFog System 1500 PSI Pump takes ordinary city water pressure, which is normally about 50-70 PSI, and “boosts” it up to 1500 PSI. The higher water pressure created by the pump enhances mist cooling and heat absorption in two ways. First, it produces a higher flow of water through the nozzle. More water being expelled from the nozzle means more cooling. Second, it creates a smaller finer mist droplet that allows the droplet to evaporate more quickly. Better evap-oration means better cooling.

There are many applications for the 1500 PSI Pump. Applications include patio cooling for homes and restaurants, greenhouses, humidification, dust control, odor control and many more.

Caution, Warning and Safety Instructions:

1. **Warning:** Before plugging in the unit for the first time, read the following section carefully. To reduce the risk of electric shock, plug in supplied grounded cord into a properly grounded receptacle. When servicing this unit, unplug power cord before attempting any service or repair.
2. **Gas motors for Outdoor use ONLY!** VFD motors for indoor or outdoor use.
3. **Install pump in a suitable place to prevent property damage, in the event that a leak should occur.**
4. Turn water off, and disconnect power to the unit when not in use for extended periods of time.
5. Do not place pump in damp or wet environments.
6. Feed system with potable cold water supply only. Do not connect pump to hot water supply.

Do not expose pump to freezing temperatures. When winterizing disconnect pump from power and water supply, and store in a dry safe place. Make sure all water is drained from the system to prevent damage in the event of a freeze.

INSTALLATION

1. Install pump above grade level on a pre-formed concrete pad (16” x 24”). This pump is non-submersible. Locate pump in a location where flooding and roof runoff does not occur to avoid water damage to the electric motor.
2. Verify water feed to pump location is potable cold water supply only.
3. Connect cold water feed to pump inlet and connect nylon tubing to pump outlet. **Important: Install 50 ft. or more of nylon tubing from the pump to the metal line to prevent line noise and vibration.**
4. Remove black shipping cap on the pump crankcase and install the red breather cap provided. Unit is pre-filled with oil and ready to operate. Oil should be half full on the sight glass when unit is off. Do not overfill.
5. Plug pump into a properly grounded receptacle. Do not use extension cords!
6. On new misting systems, flush lines before installing nozzles. The pump will not build pressure until all of the nozzles are installed.
7. Do not exceed 1500 PSI and do NOT run the pump without water.

MAINTENANCE & PARTS

Change oil every 500 hours of operation or once a year. Use approved pump oil (52025)

Proper oil level is half full on the sight gauge when the unit is off. Do not overfill. Oil capacity is 10.1 oz.

Change water filter cartridge annually or as needed. (57001) 5 Micron Cartridge.

Winter shutdown:

Unplug pump power cord, shut off water supply, remove filter bowl and drain water. Drain water out of all lines using compressed air to prevent freeze damage.

57011 5 MICRON FILTER CARTRIDGE

57006 1 MICRON FILTER CARTRIDGE



57251 PRESSURE GAUGE
0-2000 PSI



30102 ROTARY PANEL SWITCH
20 AMP



57025 CAT PUMP OIL 21 oz.



30375 SOLENOID VALVE 3/8"



30375-C CORD with DIN CONNECTOR

33053 SEAL KIT



66400K LOW WATER PRESSURE
CUT-OUT SWITCH KIT (**Optional:**
Protects pump from running dry)



47216 OIL SEAL (3 required)



30215-CAT THERMAL PROTEC-
TOR (**Optional:** Protects pump
from overheating from excessive
bypass)



33058 VALVE KIT



52000-K Drain Valve Kit
(**Optional:** Installs at low
point to nylon tubing)



PUMP PARTS



EXPLODED VIEW

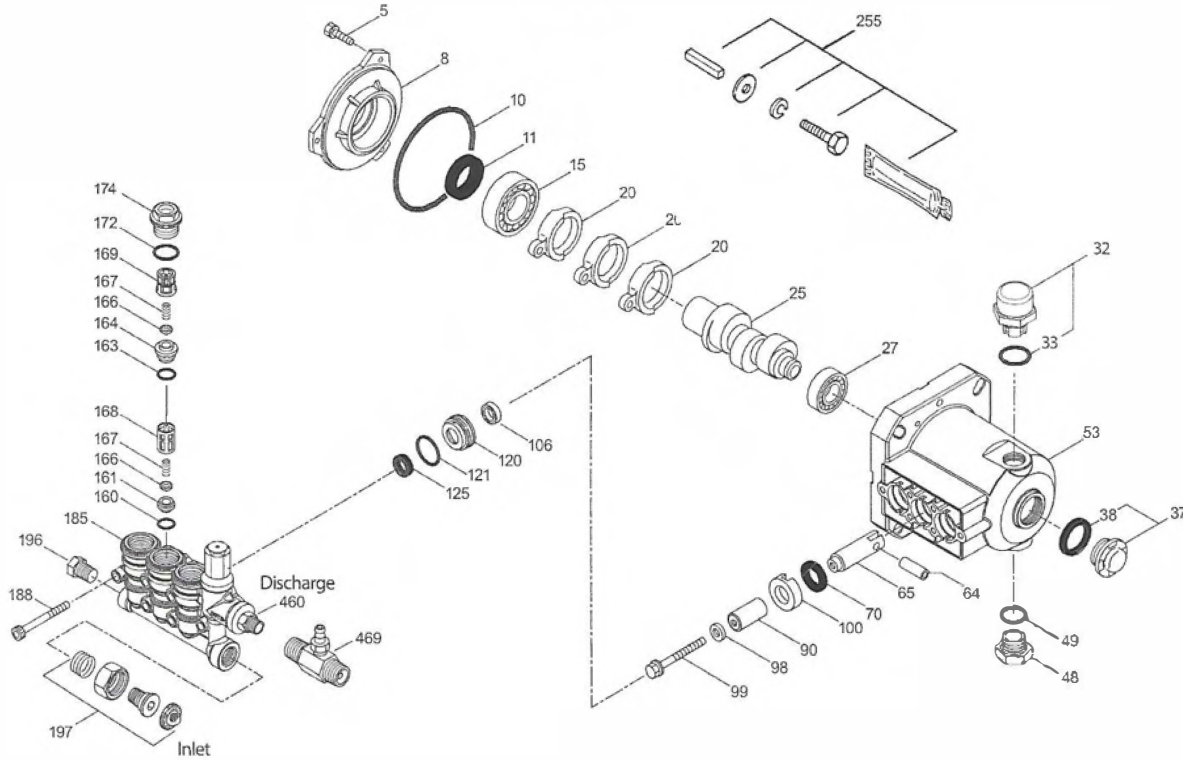

PARTS LIST

| ITEM | P/N | MATL | DESCRIPTION | QTY | ITEM | P/N | MATL | DESCRIPTION | QTY |
|------|---------------|--------|---|-----|------|---------|--------|---|-----|
| 5 | 549360 | STCP R | Screw, HH (M6x14) | 3 | 100 | 46233 | D | Retainer, Seal | 3 |
| 8 | 547153 | AL | Cover, Bearing | 1 | 106 | † 48222 | NBR | Seal, LPS w/S-Sprg - 85D | 3 |
| 10 | 14041 | NBR | O-Ring, Bearing Cover - 70D | 1 | 120 | 547357 | BB | Case, Seal | 3 |
| 11 | 55337 | NBR | Seal, Oil | 1 | 121 | 13976 | NBR | O-Ring, Seal Case - 70D | 3 |
| 15 | 14488 | STL | Bearing, Ball - Inner | 1 | 125 | 46240 | NBR | Seal, HPS w/S | 3 |
| 20 | 547048 | TNM | Rod, Connecting | 3 | 160 | 13965 | NBR | O-Ring, Seat, Inlet - 70D | 3 |
| 25 | 132183 | CM | Crankshaft, 3450 RPM, 5/8", 2.0 mm, 4DX10ER | 1 | 161 | 545177 | S | Seat, Inlet | 3 |
| | 132185 | CM | Crankshaft, 3450 RPM, 5/8", 3.0 mm, 4DX15ER | 1 | 163 | 19285 | NBR | O-Ring, Seat, Discharge - 70D | 3 |
| | 132186 | CM | Crankshaft, 3450 RPM, 5/8", 4.0 mm, 4DX20ER | 1 | 164 | 545178 | S | Seat, Discharge | 3 |
| | 132187 | CM | Crankshaft, 3450 RPM, 5/8", 5.6 mm, 4DX27ER | 1 | 166 | 46764 | S | Valve | 6 |
| | 132188 | CM | Crankshaft, 3450 RPM, 5/8", 6.2 mm, 4DX30ER | 1 | 167 | 46865 | S | Spring | 6 |
| 27 | 15710 | STL | Bearing, Ball - Outer | 1 | 168 | 543988 | PVDF | Retainer, Spring, Inlet | 3 |
| 32 | 549726 | — | Cap, Vented w/O-Ring (Rain Cap) | 1 | 169 | 49764 | PVDF | Retainer, Spring, Discharge | 3 |
| 33 | 14179 | NBR | O-Ring, Oil Filler Cap - 70D | 1 | 172 | 142807 | NBR | O-Ring, Plug - 90D | 3 |
| 37 | 92241 | — | Gauge, Bubble Oil w/Gasket | 1 | 174 | 547104 | BB | Plug, Valve (M20x1.5) | 3 |
| 38 | 44428 | NBR | Gasket, Flat Flex, Oil Gauge - 80D | 1 | 185 | 132192 | FBB | Head, Manifold w/Integral Regulator/Unloader Body | 1 |
| 48 | 44842 | NY | Plug, Drain | 1 | 188 | 549357 | STCP R | Screw, HSH (M6x60) | 6 |
| 49 | 14179 | NBR | O-Ring, Drain Plug - 70D | 1 | 196 | 22177 | BBCP | Plug, Accessory | 1 |
| 53 | 49801 | AL | Crankcase | 1 | 197 | 941516 | BB | Assy, GH, 3/8" NPT(F) | 1 |
| 64 | 46229 | CM | Pin, Crosshead | 3 | 255 | 30516 | STZP R | Assy, Bolt Mount | 1 |
| 65 | 132190 | BB | Rod, Plunger | 3 | 300 | 33053 | NBR | Kit, Seal (Incls: 98, 106, 121, 125) | 1 |
| 70 | 47215 | NBR | Seal, Oil - 70D | 3 | 310 | 76978 | NBR | Kit, Valve (Incls: 160, 161, 163, 164, 166, 167, 168, 169, 172) | 1 |
| 90 | 542403 | CC | Plunger (M16x27) | 3 | 400 | — | — | Regulator/Unloader, Integral (See Individual Parts) | 1 |
| 98 | 46730 | NBR | Washer, Seal - 90D | 3 | 460 | 107681 | BB | Fitting, Discharge | 1 |
| 99 | 542405 | S | Retainer, Plunger (M6x35) | 3 | 469 | 7231 | BB | Injector, Chemical, Fixed | 1 |

Bold part numbers are unique to a particular pump model. Italics are optional items.

[] Date of latest production change. R Components comply with RoHS Directive. † Production parts are different than repair parts.

See Tech Bulletins 002, 024, 036, 043, 055, 074, 083, 086 and 094 for additional information.

MATERIAL CODES (Not Part of Part Number): AL=Aluminum BB=Brass BBCP=Brass Chrome Plated CC=Ceramic CM=Chrome-moly D=Acetal FBB=Forged Brass NBR=Medium Nitrile (Buna-N) NY=Nylon PVDF=Polyvinylidene Fluoride S=304SS STL=Steel STCP=Steel/Chrome Plated STZP=Steel/Zinc Plated TNM=Special High Strength

NOTE: Discard Key which may come standard with most motors and use only the key included in this kit.

WARRANTY

Warranty and Statement

TriClean Air LLC warrants to its customers that TriFog System products, excluding nozzles, to be free of defects in materials and workmanship for a period of (1) year from the date of purchase to the original purchaser. With customers proof of receipt TriClean Air LLC will fix or replace the defective part or parts. TriCleanAir reserves the right to inspect the defective part or parts prior to replacement. TriClean Air will not be responsible for consequential or incidental cost or damage caused by the product failure. TriClean Air LLC, liability under this warranty is limited solely to the replacement or repair of defective parts.

Neither this warrant nor any implied warranty applies to damage or harm caused by any or all of the following:

1. Freight damage
2. Damage cause from freezing, fire, natural disaster, improper installation, chemicals, unusual characteristics of water supply.
3. Damage caused by parts, accessories, or components not obtained from or approved by TriClean Air
4. Damage due to misapplication and/or misuse.
5. Normal wear of moving parts or components affected by moving parts
6. Use with flammable materials is forbidden.

The liability of TriClean Air under the foregoing warranty is limited to the repair or replacement at the discretion of TriClean Air. The return of the entire pump or other product to TriClean Air factory must be within the warranty period, at the sole expense of the purchaser. Upon examination the returned product will be deemed to have been defective in material or workmanship.

TriClean Air, expressly warrants its pumps and other products as above stated. There are no other express warranties. Any implied warranties including implied warranty of merchantability or of fitness for a particular purpose are limited in duration to one year from the date of purchase by the original purchaser except in states that do not allow time limitations on implied warranties. There is no implied warranty of fitness for a particular purpose or merchantability when this product is put to an industrial, commercial or rental use.

No person including any dealer or representative of TriClean Air is authorized to make any representation or warranty concerning TriClean Air products on behalf of TriClean Air or to assume for TriClean Air the obligations contained in the warranty. TriClean Air reserves the right to install the same upon its existing products or products then in process or manufacture. This warranty gives you specific legal rights, and you may also have other rights, which vary from state to state.

TriClean Air LLC
400 N. St Paul
Dallas, TX 75201
Phone - 972-656-9032
www.tricleanair.com