



Unit Tag	Qty	Model No	Net Cooling	Nominal Voltage	Refrigerant Type
TCA95TSARH4603P	1	TCA95TSARH4603P	100.8	460-3-60.0	R407C

Evaporator Data		Heat Recovery Data		Performance Data	
EWT (°F)	54.00	EWT (°F)	104.00	EER (Btu/W·h)	10.89
LWT (°F)	44.00	LWT (°F)	113.00	IPLV.IP (Btu/W·h)	18.56
Design Flow Rate (USGPM)	250.00	Design Flow Rate (USGPM)	240.00		
Evap. Press. Drop (ft H2O)	15.30	Total Press. Drop (ft H2O)	15.3		
Fluid	Water	Condenser Data		Physical Data	
Strainer Press. Drop (ft H2O)	0.925	Ambient Temp. Design (°F)	95.0	Rigging Wt. (lb)	9920
Ext. Kit Press. Drop (ft H2O)	0.567	Altitude (ft)	0.000	Operating Wt. (lb)	9982
Total Press. Drop (ft H2O)	16.79	Compressor Type	Screw - Hermetic	Refrigerant Charge (lb)	308
Fouling Factor (h.ft².F/Btu)	0.000100				

Electrical Data				
Circuit	1	2	3	4
Compressor RLA	150 / 150			
Fan QTY/FLA (each)	8 / 3			
High LRA Current	160			

Single Point					
Min. Circuit Ampacity	160				
Recommended Fuse/CB Rating	200				
Max. Inverse Time CB Rating	200				
Max. Dual Element Fuse Size (A)	200				
Unit Short Circuit Withstand (STD)	5 [kA]			Operating Condition Electrical Data	
Wires Per Phase	1			Compressor kW	102.30
Wire Range (Lug Size)	3/0 AWG			Total Fan kW	8.80
Starter Type	Across The Line			Total kW	111.10

Notes:

Performance at AHRI Conditions					
Evaporator Data		Condenser Data		Performance Data	
EWT (°F)	54.00	Ambient Temp. (°F)	95.0	EER (Btu/W·h)	10.89
LWT (°F)	44.00	Altitude (ft)	0.000	IPLV.IP (Btu/W·h)	18.56
Flow Rate (USGPM)	250.00			Net Cooling Capacity	93.83
Pressure Drop (ft H2O)	15.30				
Fluid	Water				
Fouling Factor (h.ft².F/Btu)	0.000100				
Fluid Volume (USGAL)	9.100				

<https://tricleanair.com/techsheets/>

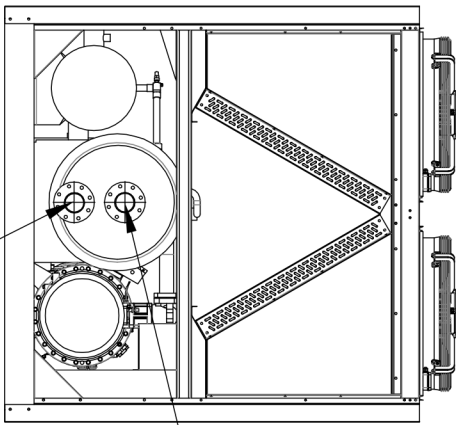
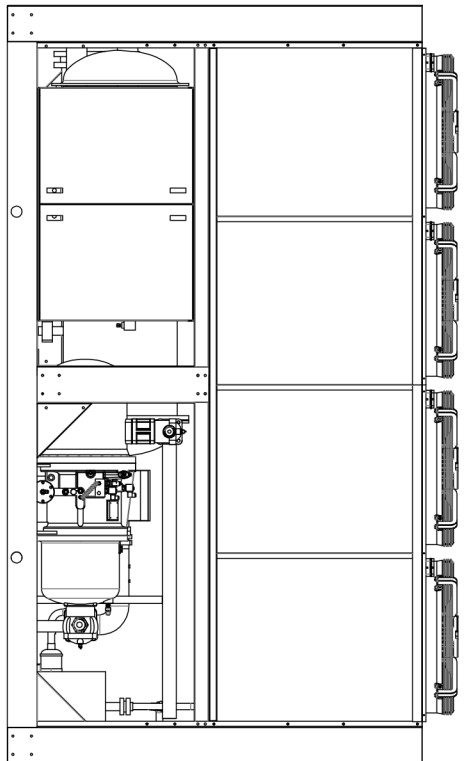

Hot Water Return DN125

Hot Water Supply DN125

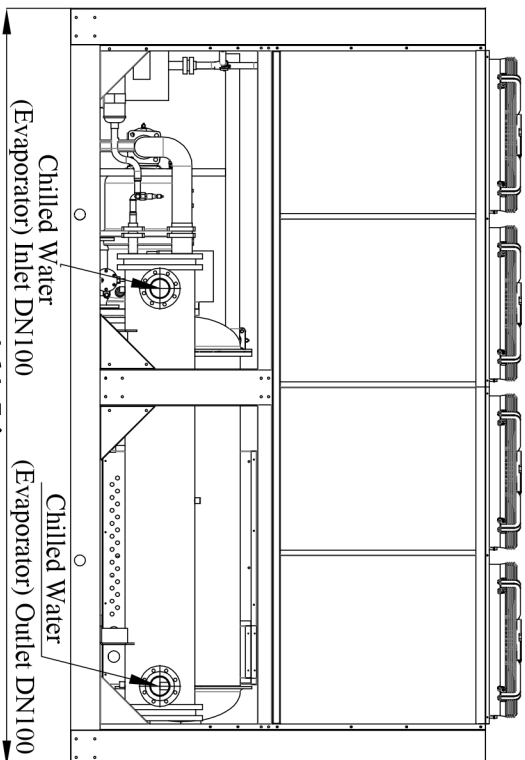

161.5 in

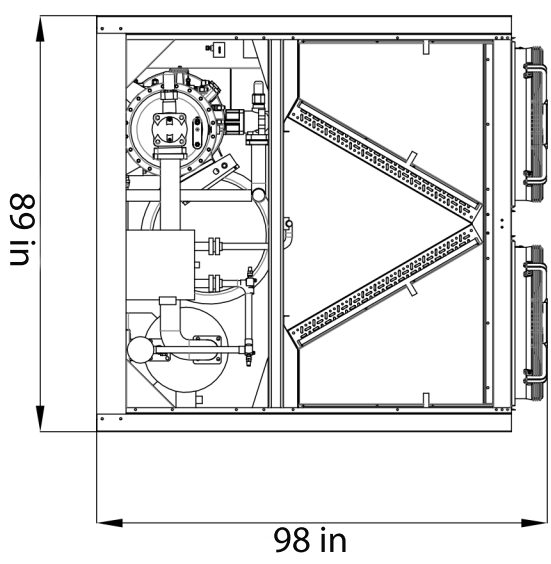

98 in

89 in

